

Industrial pressure transmitter for measuring absolute and relative pressure

Description



Technical data

Industrial pressure transducer	
Measuring range	-1...+100 bar
Overload	See table delivery spectrum over/burst pressure
Residual error Linearity/Hyst.	< ±0.4 % FS
Temperature coefficient	TCO < ±0.015 % FS / K TCG < ±0.010 % FS / K
Application temp. range	-20...+80 °C
Sensor material	Ceramic measuring cell
Housing material	Stainless steel
Seal	Viton
Pressure connection	G $\frac{1}{4}$ " / G $\frac{1}{2}$ " external thread
Connection	4-pole industrial plug, male, DIN 43650
Protection class	IP65
CE-conformity	2014/30/EU
EMC emission standard	EN 61000-6-3:2011
EMV immunity	EN 61000-6-1:2007
Version 4...20 mA	
Output signal	4...20 mA, two wires
Min. load	$R_{a[\Omega]} = (U_v[V] - 10V) / 0.02 A$
Version 0...10 V	
Output signal	0...10 V, three wires
Operation voltage	12...36 V DC / 5 mA
Version I ² C	
Output signal	I ² C-Bus
Operation voltage	3,0...5,3 V DC / 5 mA

Performance features

- Variants from vacuum to 100 bar FS
- For measuring absolute and relative pressure
- Standard output signal 0...10 V, 4...20 mA or I²C
- High-quality industrial version (stainless steel)
- Robust, media-resistant version
- Temperature compensated
- Easy to install
- Water and oil resistant
- Protection class IP65

Areas of application

- Pneumatics
- Hydraulics
- Industrial applications
- Mechanical and plant engineering
- Automation technology

Features

Properties

The stainless steel pressure sensors transmit the measured value as a calibrated and temperature-compensated standard signal 0...10 V, 4...20 mA or I²C. The portfolio of products covers the pressure range from vacuum to 100 bar full scale (FS) with graduated measuring range variants (see table).

Precise calibration at seven measuring points for three different temperatures ensures excellent precision and a very low residual temperature error.

The sensors are ideal for measuring static and dynamic relative or absolute pressure in liquids and gaseous media. Typical areas of application include pneumatics, hydraulics and industrial applications.

The robust sensor housing, compliant with protection class IP65, is made of stainless steel and has a G $\frac{1}{4}$ " or G $\frac{1}{2}$ " external thread as the media connection. The electrical connection is an industrial plug according to DIN 43650. The version with current signal is supplied via the current loop.

The version with I²C output is programmed at the factory with the address 0x78. On request, a customer-specific address can be programmed. Please order the article 0800 3000 „Programming the I²C address ex works“.

DATA SHEET

Industrial pressure transmitter for measuring absolute and relative pressure

Connection layout

Pin	Voltage output 0...10 V	Current output 4...20 mA	I ² C-Bus
1	Supply: + DC 12...36 V	Supply: + DC 14...24 V	Supply: + DC 3,0...5,3 V
2	Supply: - DC	Pressure: 4...20 mA	Supply: - DC
3	Pressure: 0...10 V	-	SCL
4	-	-	SDA



Connection diagramm

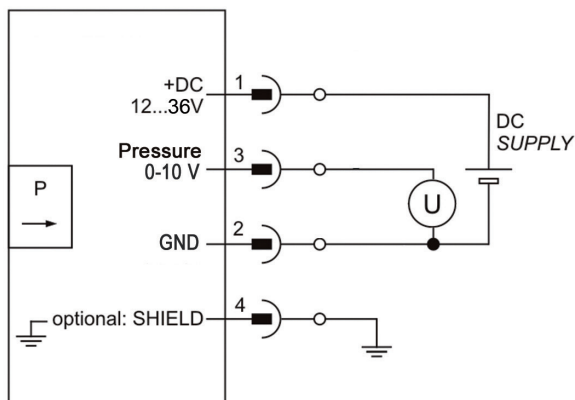

Voltage output 0...10 V, DC supply

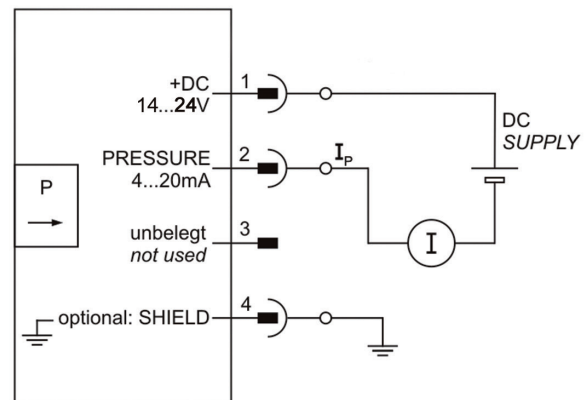

Current output 4...20 mA

Dimensions

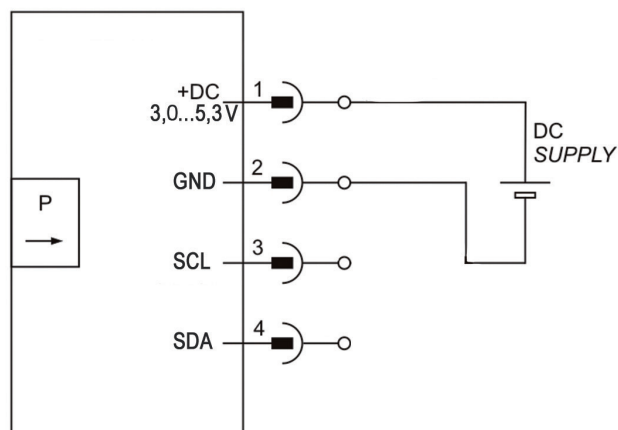

I²C

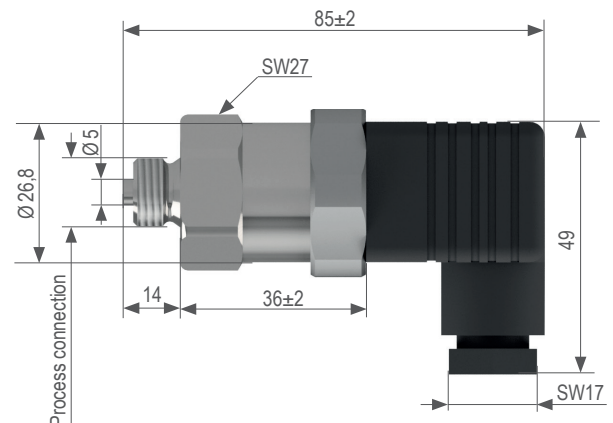

Attention

Please avoid extreme mechanical and inappropriate exposure.

The device/product is not suitable for potential explosive areas and medical-technical applications.

For more information, please visit our website: www.bb-sensors.com

DATA SHEET

Industrial pressure transmitter for measuring absolute and relative pressure

Delivery spectrum

Pressure kind	Output	Process connection	Measuring range	Over pressure	Burst pressure	Article number
relativ	0...10 V	G1/4"	-1-1 bar	3,2 bar	5 bar	0550 1191-001
relativ	0...10 V	G1/4"	0-1 bar	3,2 bar	5 bar	0550 1191-002
relativ	0...10 V	G1/4"	0-1,6 bar	3,2 bar	5 bar	0550 1191-003
relativ	0...10 V	G1/4"	0-2,5 bar	10 bar	12 bar	0550 1191-004
relativ	0...10 V	G1/4"	0-4 bar	10 bar	12 bar	0550 1191-005
relativ	0...10 V	G1/4"	0-6 bar	12 bar	18 bar	0550 1191-006
relativ	0...10 V	G1/4"	0-10 bar	20 bar	30 bar	0550 1191-007
relativ	0...10 V	G1/4"	0-16 bar	32 bar	48 bar	0550 1191-008
relativ	0...10 V	G1/4"	0-25 bar	50 bar	75 bar	0550 1191-009
relativ	0...10 V	G1/4"	0-40 bar	80 bar	120 bar	0550 1191-010
relativ	0...10 V	G1/4"	0-60 bar	120 bar	180 bar	0550 1191-011
relativ	0...10 V	G1/4"	0-100 bar	200 bar	300 bar	0550 1191-012
relativ	0...10 V	G1/2"	-1-1 bar	3,2 bar	5 bar	0550 1181-001
relativ	0...10 V	G1/2"	0-1 bar	3,2 bar	5 bar	0550 1181-002
relativ	0...10 V	G1/2"	0-1,6 bar	3,2 bar	5 bar	0550 1181-003
relativ	0...10 V	G1/2"	0-2,5 bar	10 bar	12 bar	0550 1181-004
relativ	0...10 V	G1/2"	0-4 bar	10 bar	12 bar	0550 1181-005
relativ	0...10 V	G1/2"	0-6 bar	12 bar	18 bar	0550 1181-006
relativ	0...10 V	G1/2"	0-10 bar	20 bar	30 bar	0550 1181-007
relativ	0...10 V	G1/2"	0-16 bar	32 bar	48 bar	0550 1181-008
relativ	0...10 V	G1/2"	0-25 bar	50 bar	75 bar	0550 1181-009
relativ	0...10 V	G1/2"	0-40 bar	80 bar	120 bar	0550 1181-010
relativ	0...10 V	G1/2"	0-60 bar	120 bar	180 bar	0550 1181-011
relativ	0...10 V	G1/2"	0-100 bar	200 bar	300 bar	0550 1181-012
relativ	4...20 mA	G1/4"	-1-1 bar	3,2 bar	5 bar	0550 1291-001
relativ	4...20 mA	G1/4"	0-1 bar	3,2 bar	5 bar	0550 1291-002
relativ	4...20 mA	G1/4"	0-1,6 bar	3,2 bar	5 bar	0550 1291-003
relativ	4...20 mA	G1/4"	0-2,5 bar	10 bar	12 bar	0550 1291-004
relativ	4...20 mA	G1/4"	0-4 bar	10 bar	12 bar	0550 1291-005
relativ	4...20 mA	G1/4"	0-6 bar	12 bar	18 bar	0550 1291-006
relativ	4...20 mA	G1/4"	0-10 bar	20 bar	30 bar	0550 1291-007
relativ	4...20 mA	G1/4"	0-16 bar	32 bar	48 bar	0550 1291-008
relativ	4...20 mA	G1/4"	0-25 bar	50 bar	75 bar	0550 1291-009
relativ	4...20 mA	G1/4"	0-40 bar	80 bar	120 bar	0550 1291-010
relativ	4...20 mA	G1/4"	0-60 bar	120 bar	180 bar	0550 1291-011
relativ	4...20 mA	G1/4"	0-100 bar	200 bar	300 bar	0550 1291-012

DATA SHEET

Industrial pressure transmitter for measuring absolute and relative pressure

Delivery spectrum

Pressure kind	Output	Process connection	Measuring range	Over pressure	Burst pressure	Article number
relativ	4...20 mA	G1/2"	-1-1 bar	3,2 bar	5 bar	0550 1281-001
relativ	4...20 mA	G1/2"	0-1 bar	3,2 bar	5 bar	0550 1281-002
relativ	4...20 mA	G1/2"	0-1,6 bar	3,2 bar	5 bar	0550 1281-003
relativ	4...20 mA	G1/2"	0-2,5 bar	10 bar	12 bar	0550 1281-004
relativ	4...20 mA	G1/2"	0-4 bar	10 bar	12 bar	0550 1281-005
relativ	4...20 mA	G1/2"	0-6 bar	12 bar	18 bar	0550 1281-006
relativ	4...20 mA	G1/2"	0-10 bar	20 bar	30 bar	0550 1281-007
relativ	4...20 mA	G1/2"	0-16 bar	32 bar	48 bar	0550 1281-008
relativ	4...20 mA	G1/2"	0-25 bar	50 bar	75 bar	0550 1281-009
relativ	4...20 mA	G1/2"	0-40 bar	80 bar	120 bar	0550 1281-010
relativ	4...20 mA	G1/2"	0-60 bar	120 bar	180 bar	0550 1281-011
relativ	4...20 mA	G1/2"	0-100 bar	200 bar	300 bar	0550 1281-012
relativ	I ² C	G1/4"	-1-1 bar	3,2 bar	5 bar	0550 1391-001
relativ	I ² C	G1/4"	0-1 bar	3,2 bar	5 bar	0550 1391-002
relativ	I ² C	G1/4"	0-1,6 bar	3,2 bar	5 bar	0550 1391-003
relativ	I ² C	G1/4"	0-2,5 bar	10 bar	12 bar	0550 1391-004
relativ	I ² C	G1/4"	0-4 bar	10 bar	12 bar	0550 1391-005
relativ	I ² C	G1/4"	0-6 bar	12 bar	18 bar	0550 1391-006
relativ	I ² C	G1/4"	0-10 bar	20 bar	30 bar	0550 1391-007
relativ	I ² C	G1/4"	0-16 bar	32 bar	48 bar	0550 1391-008
relativ	I ² C	G1/4"	0-25 bar	50 bar	75 bar	0550 1391-009
relativ	I ² C	G1/4"	0-40 bar	80 bar	120 bar	0550 1391-010
relativ	I ² C	G1/4"	0-60 bar	120 bar	180 bar	0550 1391-011
relativ	I ² C	G1/4"	0-100 bar	200 bar	300 bar	0550 1391-012
relativ	I ² C	G1/2"	-1-1 bar	3,2 bar	5 bar	0550 1381-001
relativ	I ² C	G1/2"	0-1 bar	3,2 bar	5 bar	0550 1381-002
relativ	I ² C	G1/2"	0-1,6 bar	3,2 bar	5 bar	0550 1381-003
relativ	I ² C	G1/2"	0-2,5 bar	10 bar	12 bar	0550 1381-004
relativ	I ² C	G1/2"	0-4 bar	10 bar	12 bar	0550 1381-005
relativ	I ² C	G1/2"	0-6 bar	12 bar	18 bar	0550 1381-006
relativ	I ² C	G1/2"	0-10 bar	20 bar	30 bar	0550 1381-007
relativ	I ² C	G1/2"	0-16 bar	32 bar	48 bar	0550 1381-008
relativ	I ² C	G1/2"	0-25 bar	50 bar	75 bar	0550 1381-009
relativ	I ² C	G1/2"	0-40 bar	80 bar	120 bar	0550 1381-010
relativ	I ² C	G1/2"	0-60 bar	120 bar	180 bar	0550 1381-011
relativ	I ² C	G1/2"	0-100 bar	200 bar	300 bar	0550 1381-012

DATA SHEET

Industrial pressure transmitter for measuring absolute and relative pressure

Delivery spectrum

Pressure kind	Output	Process connection	Measuring range	Over pressure	Burst pressure	Article number
absolut	0...10 V	G1/4"	0-1 bar	3,2 bar	5 bar	0550 2191-001
absolut	0...10 V	G1/4"	0-2 bar	10 bar	12 bar	0550 2191-002
absolut	0...10 V	G1/4"	0-5 bar	12 bar	18 bar	0550 2191-003
absolut	0...10 V	G1/4"	0-10 bar	20 bar	30 bar	0550 2191-004
absolut	0...10 V	G1/4"	0-20 bar	50 bar	75 bar	0550 2191-005
absolut	0...10 V	G1/4"	0-50 bar	120 bar	180 bar	0550 2191-006
absolut	0...10 V	G1/2"	0-1 bar	3,2 bar	5 bar	0550 2181-001
absolut	0...10 V	G1/2"	0-2 bar	10 bar	12 bar	0550 2181-002
absolut	0...10 V	G1/2"	0-5 bar	12 bar	18 bar	0550 2181-003
absolut	0...10 V	G1/2"	0-10 bar	20 bar	30 bar	0550 2181-004
absolut	0...10 V	G1/2"	0-20 bar	50 bar	75 bar	0550 2181-005
absolut	0...10 V	G1/2"	0-50 bar	120 bar	180 bar	0550 2181-006
absolut	4...20 mA	G1/4"	0-1 bar	3,2 bar	5 bar	0550 2291-001
absolut	4...20 mA	G1/4"	0-2 bar	10 bar	12 bar	0550 2291-002
absolut	4...20 mA	G1/4"	0-5 bar	12 bar	18 bar	0550 2291-003
absolut	4...20 mA	G1/4"	0-10 bar	20 bar	30 bar	0550 2291-004
absolut	4...20 mA	G1/4"	0-20 bar	50 bar	75 bar	0550 2291-005
absolut	4...20 mA	G1/4"	0-50 bar	120 bar	180 bar	0550 2291-006
absolut	4...20 mA	G1/2"	0-1 bar	3,2 bar	5 bar	0550 2281-001
absolut	4...20 mA	G1/2"	0-2 bar	10 bar	12 bar	0550 2281-002
absolut	4...20 mA	G1/2"	0-5 bar	12 bar	18 bar	0550 2281-003
absolut	4...20 mA	G1/2"	0-10 bar	20 bar	30 bar	0550 2281-004
absolut	4...20 mA	G1/2"	0-20 bar	50 bar	75 bar	0550 2281-005
absolut	4...20 mA	G1/2"	0-50 bar	120 bar	180 bar	0550 2281-006
absolut	I ² C	G1/4"	0-1 bar	3,2 bar	5 bar	0550 2391-001
absolut	I ² C	G1/4"	0-2 bar	10 bar	12 bar	0550 2391-002
absolut	I ² C	G1/4"	0-5 bar	12 bar	18 bar	0550 2391-003
absolut	I ² C	G1/4"	0-10 bar	20 bar	30 bar	0550 2391-004
absolut	I ² C	G1/4"	0-20 bar	50 bar	75 bar	0550 2391-005
absolut	I ² C	G1/4"	0-50 bar	120 bar	180 bar	0550 2391-006
absolut	I ² C	G1/2"	0-1 bar	3,2 bar	5 bar	0550 2381-001
absolut	I ² C	G1/2"	0-2 bar	10 bar	12 bar	0550 2381-002
absolut	I ² C	G1/2"	0-5 bar	12 bar	18 bar	0550 2381-003
absolut	I ² C	G1/2"	0-10 bar	20 bar	30 bar	0550 2381-004
absolut	I ² C	G1/2"	0-20 bar	50 bar	75 bar	0550 2381-005
absolut	I ² C	G1/2"	0-50 bar	120 bar	180 bar	0550 2381-006