

DATA SHEET



Thermal flow-sensor for measuring gas

Description



Characteristic features

- Thermal optimized and efficient sensor structure
- Flow measurement in gases of 0...0,1 m/s to 0...100 m/s
- Fast reaction time
- No mechanically moved parts
- Good reproducibility and long-term stability
- Ideal price-performance ratio
- Easy to install in custom-build housing

Typical areas of application

- Gaseous measuring media
- Building automation
- Automotive engineering
- Medical engineering
- Device monitoring
- Cooling devices
- Food industry

Technical data

Flur-sensor FLW-122	
Measuring range flow	0...100 m/s
Measuring principle	thermal
Response sensitivity	0,01 m/s
Accuracy	<3%
Reaction time T63	approx. 2 s
Operating temperature	-20...+150 °C
Temperature sensitivity	<0,1%/K depending on electronics and calibration
Electrical connection	3-polig
Nominal resistance heater	RH(0°C) = 45 Ω 5%
Nominal resistance sensor	RS(0°C) = 1200 Ω ±5%
Max. supply voltage	typ. 2-5 V bei Δ T=30 K (0 <Vström<100 m/s)
Max. heater voltage	3 V
Substrate material	Special ceramic-poor conductor of heat
Dimensions (without pins)	(LxBxH) 6,9x,2,4x0,6 mm
Art.- no.	FLW-122

Features

The FLW-122 is a thermal sensor for measuring flow in gases.

It contains two platinum resistance elements in one chip. While the small, low-ohm element serves as heater, the high-ohm element is used to measure the reference temperature. Through the evaluation unit both Pt-elements are switched in a full bridge, so that through the applied voltage an adjustment on a firstly defined temperature difference between both Pt-elements takes place.

Since the heatloss of the heating element is dependent on the stream speed, the voltage which is fitting to the bridge poses a direct gauge for the stream speed.

Due to the little sensor mass there are fast response times and short heating periods. The device does not have any movable mechanical parts, so it is long-living and precise in a measuring range of 0 to 100 m/s. It is ideally suited for the building automation, automotive engineering and medical engineering because of its high reproducibility and long-term stability.

DATA SHEET



Thermal flow-sensor for measuring gas

Dimensions

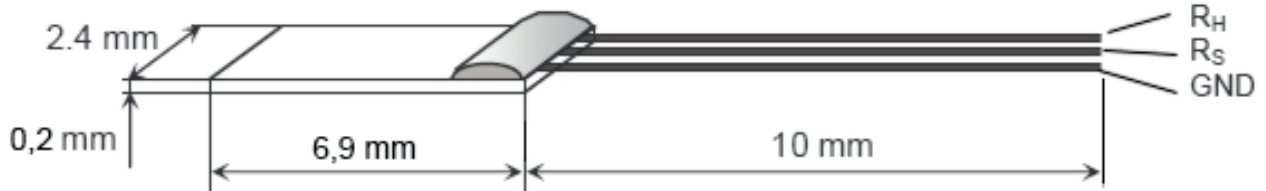

Example circuit

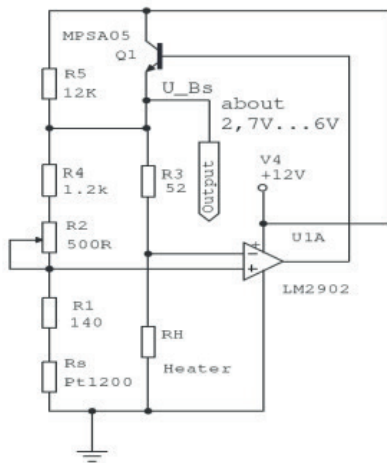

Both elements (Heater RH and sensor RS) can be switched in a bridge. The resistors R1,R2 and R3 determine the temperature difference (ΔT) between RS and RH. This is the condition to which the voltage fitting to the bridge is controlled.

When the stream speed changes, the heat loss of the heater changes too which affects the needed performance to hold up the temperature difference between RH and RS. The needed voltage at the bridge input therefore is a gauge for the stream speed.

The values for R1 .. R3 are dependent on the temperature difference (ΔT) and the medium that has to be measured. For air, these can be taken from the circuit suggestion below for a function test. R2 should be able to be compensated $\pm 10\%$ for calibration purposes. Individual calibration is always necessary for the respective application.