

# OPERATION MANUAL



## Brightness-sensor 0...1000 Lux with transmitter 0...10 V

### Description



### Features

- Standard signal 0...10 V with DC supply
- Customized measuring range up to 0...1000 Lux
- 3-point calibrated and linearized
- High long term stability
- Sensor and transmitter combined in one housing
- High-quality plastic housing (IP54)

### Applications

- Building automation, dark/light switching processes
- Sun sensors
- Brightness sensor for rain-protected weather stations
- Brightness sensor for switching consumers in applications with solar panels
- Brightness sensor for use at high sunlight

### Technical Datas

Measuring range	0...1000 Lux
Sensor	Photodiode
Maximum spectral sensitivity	600 nm
Output scale	0...1000 FS
Accuracy	±30 %
Operating temperature	-20...+75 °C
CE-Conformance	2014/30/EU
EMV-Noise emission	EN 61000-6-3:2011
EMV-Noise withstanding	EN 61000-6-1:2007
Power supply	12...24 V/DC
Output supply	0...10V DC
Over voltage protection	Varistor and RC-filter
Dimensions (B x H x T) without the coupling of the brightness-sensor	59 x 65 x 38
Article	Art.-No.
Brightness-Sensor with Transmitter 0...10 V	0555 3002

The brightness sensor is a light sensor for the building automation. It is protected against overvoltage and transients and is suitable for a continuous use.

For the measurement of luminous intensity a precise and long-term stable photodiode with industrial performance is used. The processing of the measured signal is done through advanced sensor technology with an ASIC.

The three-point calibration results in a high precision over a wide range of brightness for precise control tasks.

A variety of possible applications results from the determination of the brightness for the dynamic control of devices in the home and building automation, for example as a sun sensor.

# OPERATION MANUAL



## Brightness-sensor 0...1000 Lux with transmitter 0...10 V

### Installation of the brightness sensor

The installed sensor could be directly attached to the surface of the combined transducer. Please have a look at the drawing where you can see the boreholes for the fixation screws. Look out for a rain-protected installation.

### Connection

For the connection shielded connection cables should preferentially be used. Especially in EMI-disturbed areas this has to be taken into account. The shielding has to be grounded.

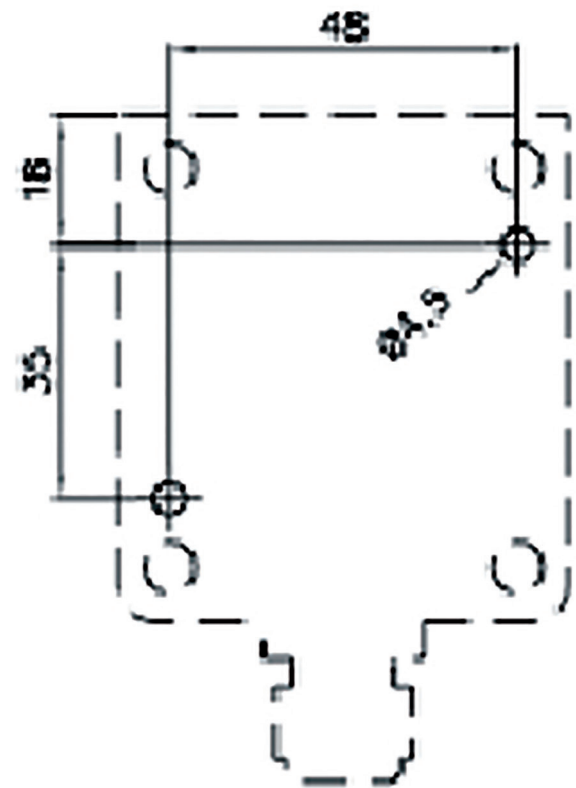
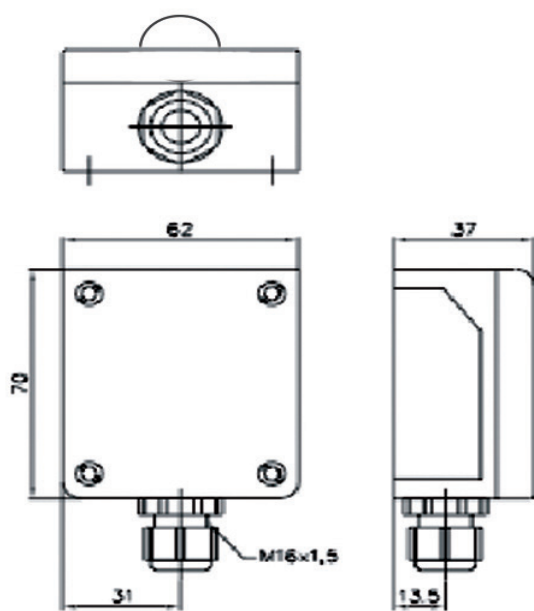

### Attention

Please avoid extreme mechanical and inappropriate exposure.

The device/product is not suitable for potential explosive areas and medical-technical applications.