

OPERATION MANUAL



HYTE humidity- and temperature-measurement system wall mounting FF-GLT-10V-series

Description



Characteristic features

- Inconspicuous wall mounted housing
- Standard signal 0...10 V
- Linearised and temperature compensated measurements
- High long-term stability, innovative technology
- Integrated sensors
- Optional with Pt1000 sensor available

Areas of application

- Indoor humidity and temperature measurement
- Building technology
- Industrial measurement and control technology
- Climatic record
- Home automation

Technical data

FF-GLT-10V-series		
Measuring range	Humidity temperature	0...100 % RH, non-condensing -30...+70 °C
Accuracy	Humidity- temperature	±3 % RH (30...90 % RH) ±0,7 ° K (0...+40 °C)
Outputs	Humidity temperature	0...100 % RH according to 0...10 V -30...+70 °C according to 0...10 V
Response time	Humidity	approx. 25 sec.
CE-conformance		2014/30/EU
EMV noise emission		EN 61000-6-3:2011
EMV noise immunity		EN 61000-6-1:2007
Housing material		ABS
Connection cable (-EXT)		Screw terminal 0,75 mm ²
Power supply		12...24 V AC/DC
Overvoltage protection		Varistor and RC-Filter
Dimensions (LxWxH)		71x71x27 mm

Article	Art.-No.
HYTE humidity system 10 V TYP TE0	FF-GLT-10V-TE0
HYTE humidity and temperature system 10 V TYP TE1	FF-GLT-10V-TE1
HYTE Humidity 10 V and passive Pt1000 temperature system TYP TEPT	FF-GLT-10V-TEPT

Functional description

In addition to low pricing, the building automation branch sets high performance requirements on measurement systems. Long term stability by continuous use, protection against surges and transients, power supply through DC and AC options and high accuracy level are some of the needs of these applications. The temperature sensor is designed specifically for these requirements, and with its latest sensor technology and innovative design using an ASIC it is specially designed for use in this area.

For the measurement of relative humidity, a precise and long-term stable polymer capacitive sensing element with industrial performance is used. For measuring the temperature, a platinum sensor is used whose values are also converted into a standard signal.

The power supply of 0...10 V version is available with DC or AC power supply.

Due the large contact area and the designated terminals, a simple and quick connection is ensured.



OPERATION MANUAL



HYTE humidity- and temperature-measurement system wall mounting FF-GLT-10V-series

Power supply

The humidity and temperature measurement system may alternatively be powered with DC or AC voltage or with unfiltered rectified voltage. With AC power, the base of the transformer and to signal ground are made of the connection of additional sensors must necessarily in phase. When fed with unfiltered rectified voltage must be negative to the reference mass and Plus + to be switched DC / AC 24 V. Incorrect connection leads to malfunction or damage the electronics!

Justage

The sensors are durable and maintenance free in a clean atmosphere. Recalibration is not necessary in most cases. For the humidity and temperature channel is a potentiometer on the main board which can be adjusted to the pitch as needed.

The calibration requires a specific knowledge and is only recommended by experienced personnel.

Measuring the signal voltage

To avoid measurement errors due to lead resistance and the supply current over the grounding line is at the 0...10 V
Provide a separate execution ground line for the signal voltage.

Connection

For the connection, only shielded cable should be used. It should be noted, especially in EMI noisy environment. The shielding must be grounded. Before you connect, check if the supply voltage agrees with the data in the specified operating voltage.

Attention

Please avoid extreme mechanical and inappropriate exposure.

The device/product is not suitable for potential explosive areas and medical-technical applications.

Drilling template

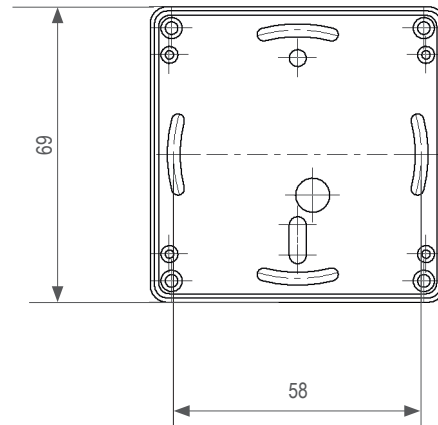

Please make sure, the ventilation slots are top and bottom.

Dimensions

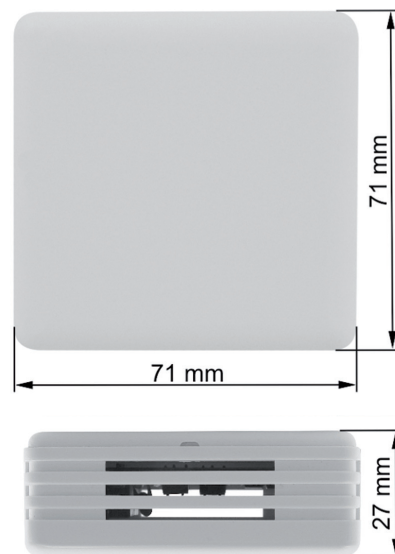

Product options

Article number	Function
FF-GLT-10V-TE0	without temperature measurement (only humidity measurement)
FF-GLT-10V-TE1	with temperature measurement
FF-GLT-10V-TEPT	with Pt1000, dry contact

OPERATION MANUAL



HYTE humidity- and temperature-measurement system wall mounting FF-GLT-10V-series

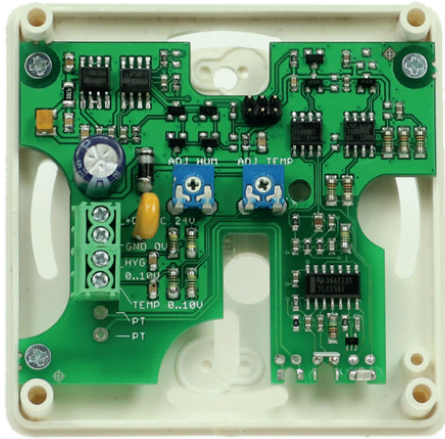

Pin	Function	Description
1	+DC/AC 24 V	Operating voltage
2	GND 0 V	Operating potential
3	Hygro 0...10 V	Humidity output 0...10 V
4	Temp. 0...10 V	Temperature output 0...10 V
5	Pt1000	Temperature sensor (passiv)
6	Pt1000	Temperature sensor (passiv)

- 1 +DC 24 V
- 2 GND
- 2 HYGRO
- 4 TEMP
- 5 PT
- 6 PT

The Pt1000 2-wire is looped through floating. The line resistance is compensated. If desired, other resistors, for example, NTC sensors are possible!

The measurement of the output signal should be done with separate signal ground, to avoid measurement errors due to voltage drop across the supply ground.

For further information, please visit our website:
www.bb-sensors.com

Humidity measuring 0...10 V
and passive Pt1000 for temperature measuring

