

OPERATION MANUAL

Indicator N1500

Description



Content

| | |
|---|----|
| Foreword | 02 |
| General Information | 02 |
| Symbols Employed | 03 |
| Warning Signs | 03 |
| Safety Instructions | 04 |
| Intended Use | 04 |
| Disposal | 04 |
| 1. Product Description | 05 |
| 2. Scope of Delivery | 05 |
| 3. Device Description | 05 |
| 3.1. Description of the buttons on the front of the indicator | 06 |
| 4. Installation | 06 |
| 5. Electrical Connection | 07 |
| 5.1. Power supply | 07 |
| 5.2. Alarm outputs | 08 |
| 5.3. Input signal connection | 08 |
| 5.4. Digital input | 09 |
| 5.5. 24V DC Output | 09 |
| 5.6. Analog Output | 09 |
| 5.7. RS485 Interface | 09 |
| 6. Operation | 10 |
| 6.1. Program level flow chart | 10 |
| 6.2. Operation level | 11 |
| 6.3. Alarm level | 11 |
| 6.4. Alarm functions | 12 |
| 6.5. Special alarm features | 12 |
| 7. Function level | 14 |
| 7.1. Min- Max- Functions | 14 |
| 7.2. Function key (F-key) | 14 |
| 7.3. Digital input functions | 14 |
| 7.4. Filter, Offset and serial Kommunikation | 15 |
| 8. Configuration | 16 |
| 8.1. Input type and display parameter | 16 |
| 8.2. Scaling and display range for analog inputs | 17 |
| 8.3. Linearization level | 18 |
| 8.4. Calibration level | 18 |
| 9. Error messages | 19 |
| 10. Serial number | 19 |
| 11. Technical Data | 19 |
| 12. Ordering information | 20 |

OPERATION MANUAL



Indicator N1500

Foreword

Dear customer,

We thank you for having purchased the Indicator N1500 and we are very glad that you decided to buy a product of **B+B Thermo-Technik GmbH**. We hope this product will fully satisfy you and will assist you effectively in your work. This Device has been developed to be technically highly up-to-date and has been designed in accordance with the regnant European and German national directives and rules. For a proper and effective usage of the product the customer shall observe the following Operating Instructions. In the case that against one's expectations any trouble occurs which you can not resolve yourself, please contact our service centers or our authorized dealer. We will provide you rapid and competent help to minimize the risk of long time outfalls.

The following operating Instruction is an indispensable part of this Product. It contains important advices for the starting up and further use of the device.

General information

This Operation Manual is intended to serve as an aid in the proper setup, installation and operating of the B+B product.

All essential details of the equipment and all actions required on the part are clearly presented and explained. We thus ask that you read this manual carefully before proceeding to work with the equipment. Keep this manual available for ready reference in a convenient and conspicuous location near the equipment.

Symbols employed

| Sign | Meaning | Notice |
|------|------------------------|--|
| | Advice | It is necessary to read the following advices before using the product. The used symbols in the manual acts first of all as eye catcher for security risks. The symbols do not replace the security advices. The text must be read completely. |
| | Necessarily to observe | This symbol designates important advices and tips which are necessary for the success of a procedure. They have to be followed in order to get good results. |

Warning signs

| Sign | Meaning |
|------|--|
| | This symbol advises the user of danger for persons, material or environment. The text gives information that must be necessarily followed to avoid any risks |
| | Caution against hot surfaces (BGV A8, GUV-V A8/W26) and hot liquids or substances |
| | Caution against liquids and hot substances |
| | Caution against dangerous explosive substances (BGV A8, GUV-V A8/W02) |
| | Caution against moving machines (W29) Caution against moving parts |
| | Caution against electromagnetic fields (BGV A8, GUV-V A8/W12) |
| | Caution against severe cold (BGV A8, GUV-V A8/W17ice) |



OPERATION MANUAL



Indicator N1500

| | |
|---|--|
|  | Caution against dangerous high electrical voltage (BGV A8, GUV-V A8/W08) |
|  | Caution against dangerous explosive atmosphere (BGV A8, GUV-V A8/W21) |
|  | Electronic waste |

Safety instructions

For damages caused by failure to observe these safety and operating instructions, takes over the B + B Thermo-Technik GmbH is not liable.

This device has been designed and tested in accordance to the safety regulations for electronic devices.

However, its trouble-free operation and reliability cannot be guaranteed unless the standard safety measures and special safety advises given in this manual will be adhered to when using it.

Trouble-free operation and reliability of the device can only be guaranteed if it is not subjected to any other climatic conditions than those stated under "Specification".

If the device is transported from a cold to a warm environment condensation may result in a failure of the function. In such a case make sure the device temperature has adjusted to the ambient temperature before trying a new start-up.

If device is to be connected to other devices the circuitry has to be designed most carefully. Internal connection in third party devices (e.g. connection GND and earth) may result in not-permissible voltages impairing or destroying the device or another device connected.

Warning:

Only devices with mains input: If device is operated with a defective mains power supply (e.g. short circuit from mains voltage to output voltage) this may result in hazardous voltages at the device (e.g. at sensor socket).

If there is a risk whatsoever involved in running it, the device has to be switched off immediately and to be marked accordingly to avoid re-starting. Operator safety may be at risk if:

- there is visible damage to the device
- the device is not working as specified
- the device has been stored under unsuitable conditions for a longer time

In case of doubt, please return device to manufacturer for repair or maintenance.

Caution:

Do not use these product as safety or emergency stop devices, or in any other application where failure of the product could result in personal injury or material damage. Failure to comply with these instructions could result in death or serious injury and material damage.

Intended Use

The use of the unit in fields other than those indicated under "SAFETY INSTRUCTIONS" is not allowed for safety reasons.

This instruction manual does not at all substitute any additional instruction manual of connected accessory!

Disposal

This unit has been marked in accordance with the European Device 2002/96/EC on waste electrical and electronic equipment (WEEE)

At the end of its operating life-time, dispose of the unit as electrical scrap.

Please ask either **B+B Thermo-Technik GmbH** or your specialist dealer for information on your local collection point.

Within the scope of application of this Directive, **B+B Thermo-Technik GmbH** is responsible for proper disposal of this unit.



OPERATION MANUAL



Indicator N1500

1. Product description

The powerful indicator N1500 offers among its universal input and the 2 relay outputs, in general used as alarm outputs, many other functions. The MIN- and MAX-values can be prompted with just a keystroke. Also there is a HOLD and a PEAK-HOLD-Function. The high tact frequency allows the N1500 indicator to monitor fast processes. It offers also the possibility to linearise the measurement signal when using non-linear input signals (mV, V, mA).

- Universal input
- 2 or 4 Relay outputs
- 6 Alarm features
- Linearization of mV-, V-, mA-Signals
- Voltage output 24V AC/DC for external 2- or 4-wire transmitter
- Memory for MAX and MIN values, hold and peak features

2. Scope of delivery

| Articlename | Articleno. | Description |
|---|--------------|---|
| Indictaor N1500 with 100 to 240 v AC | 0556 0105 | 1 x Indicator N1500, 1 x Operation manual |
| Indicator N1500 with 24 V AC/DC | 0556 0105-01 | 1 x Indicator N1500, 1 x Operation manual |
| Indicator N1500 with 4...20 mA | 0556 0105-02 | 1 x Indicator N1500, 1 x Operation manual |
| Indicator N1500 24 V AC/DC with RS485-interface | 0556 0105-03 | 1 x Indicator N1500, 1 x Operation manual |

The identification label is on the rear-panel of the indicator. Please check if the features described are in accordance with your order.

3. Device description

The front of the indicator has two essential components: a large red 6-digit LED-display and the silicon rubber keypad with 5 buttons. The following figure shows the front panel of the indicator:

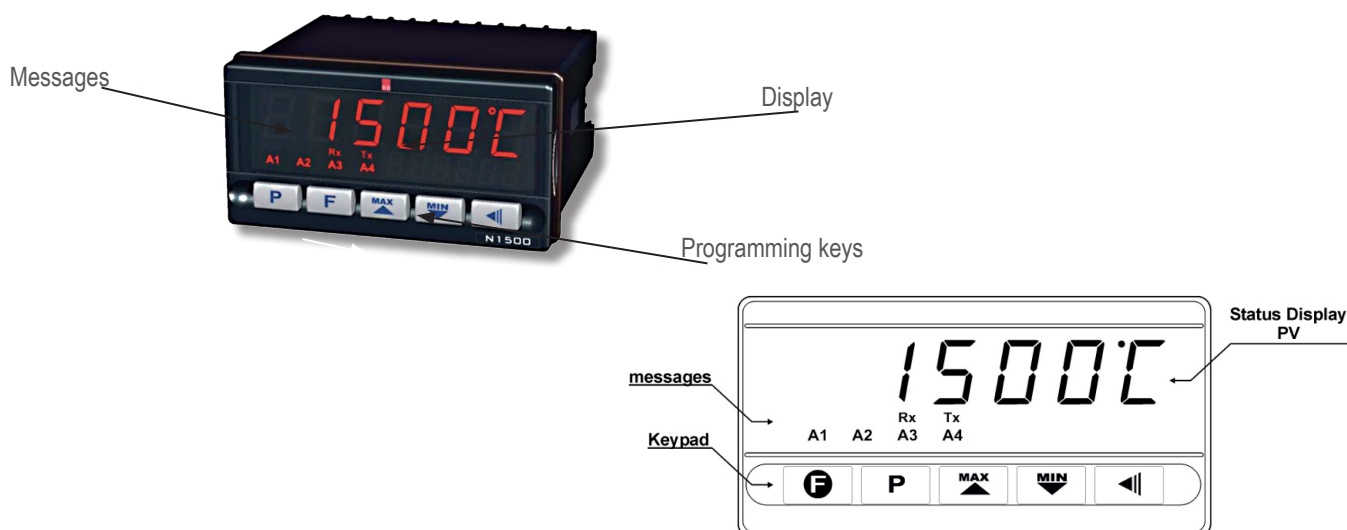

OPERATION MANUAL



Indicator N1500

- P** **cription of the buttons on the front of the indicator**
Program-key (P-key): press this button to access and to navigate through the menu of the actual displayed configuration level. To change to the next program level press the P-key and the back-key simultaneously.
- MAX** **Back-key:** press this button to go to the previous menu in the actual program level.
- MIN** **Up-key:** press this button to augment the displayed configuration value or to display the Max-V alue.
- F** **Down-key:** press this button to diminish the displayed configuration value or to display the Min-V alue.

Function-key (F-key): this button is used for pre-programmed functions as explained in Section 7.2.

4. Installation

The indicator should be installed in a panel cut-out as specified in the technical data. Please follow the steps in the sequence of steps described below:

1. Prepare a panel cutout of 93 x 45 mm
2. Remove the white mounting bracket from the device
3. Insert the device into the front of the panel cut, and be careful for the correct positioning of the seal
4. Slide the fixing clamps from the rear of the housing until they are under tension and the detents of the ratchet is engaged
5. Please make sure that the maximum operating temperature is maintained and adequate ventilation is provided to prevent overheating of the device.

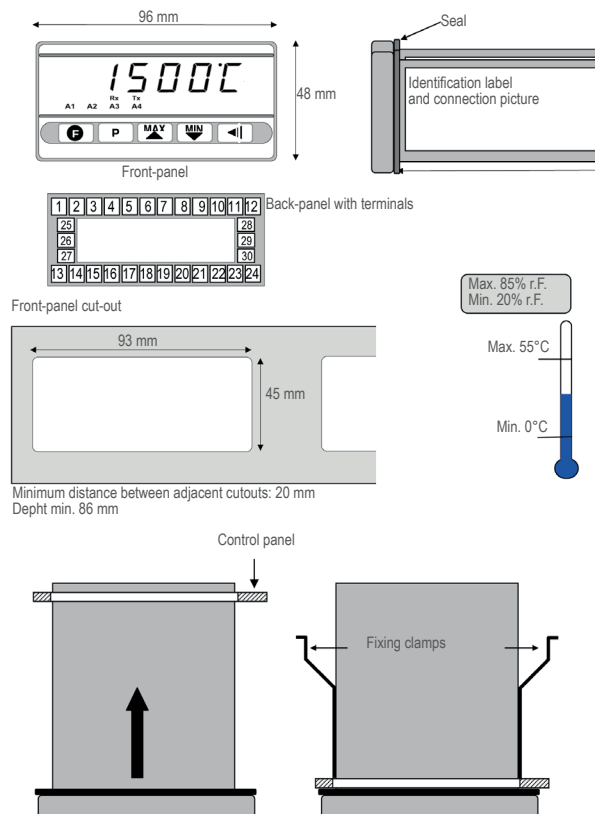

OPERATION MANUAL



Indicator N1500

5. Electrical connection

The terminals are located on the back of the indicator. They are numbered 1 to 30. In the standard version, the connecting terminals are missing 3-6 (connections for the optional alarm 3 and 4), terminals 15, 18 to 20, terminals 25 to 27 (terminals for the RS485 interface) and the terminals 28 to 30 (output 4-20 mA for the process variable transmission).

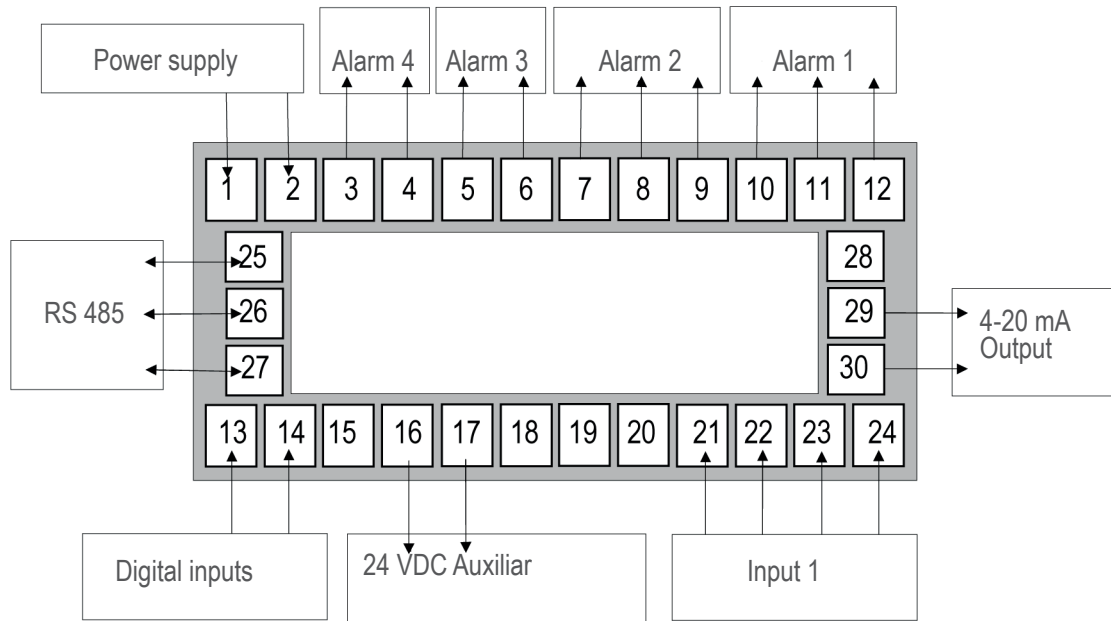

To avoid false readings or damage to the indicator, the information of the electrical connections are strictly to follow.

5.1. Power supply

The connections should be properly done at the terminals 1 or 2.

Standard version: 100...240V AC ($\pm 10\%$) 50-60 Hz or

Low-Voltage version: 24V AC/DC ($\pm 10\%$) max. 9 VA

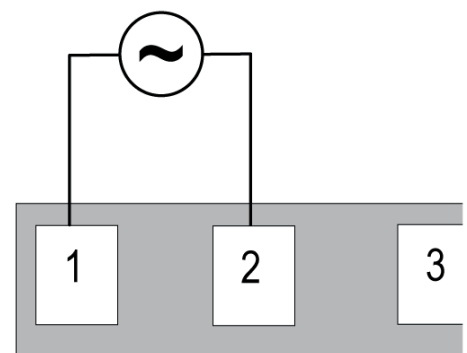

The type of the ordered and delivered version (standard or low-voltage version) may be found on the device housing. Make sure that the values correspond to the power supply as specified in the specifications. The power supply should not exceed the stated maximum values.

The device does not have a switch for power supply interruption or an electronic protection against short circuits and overcurrent. B+B Thermo-Technik GmbH assumes no liability for damages that occur due such events. The user must provide external protection devices to prevent such damage.



OPERATION MANUAL



Indicator N1500

5.2. Alarm outputs

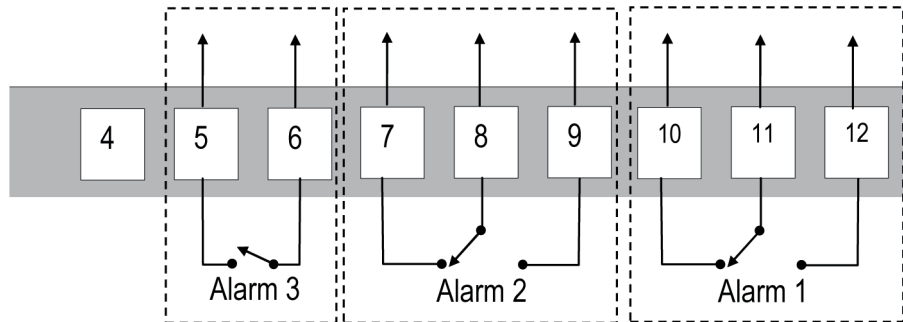

SPDT Relais (Alarm 1 und 2): max. 1,5 A / 240 V AC (max. 3A / 30 V DC), resistive load
 SPST Relais (Alarm 3 und 4): max. 13 A / 250 V AC (max. 3A / 30 V DC), resistive load

The indicator is equipped with 2 alarm outputs (SPDT relay to the connector terminals 10, 11 and 12 for alarm 1, and 7, 8 and 9 for alarm 2). Optional a third alarm output (SPST relay, terminals 5 and 6) and a fourth alarm output (SPST relay, terminals 3 and 4) possible. The SPDT-relay can be used when certain (alarm) situations occur (eg. limit value is exceeded) to switch between two external circuits. The SPST relay can open and close an external circuit.

5.3. Input signal connection

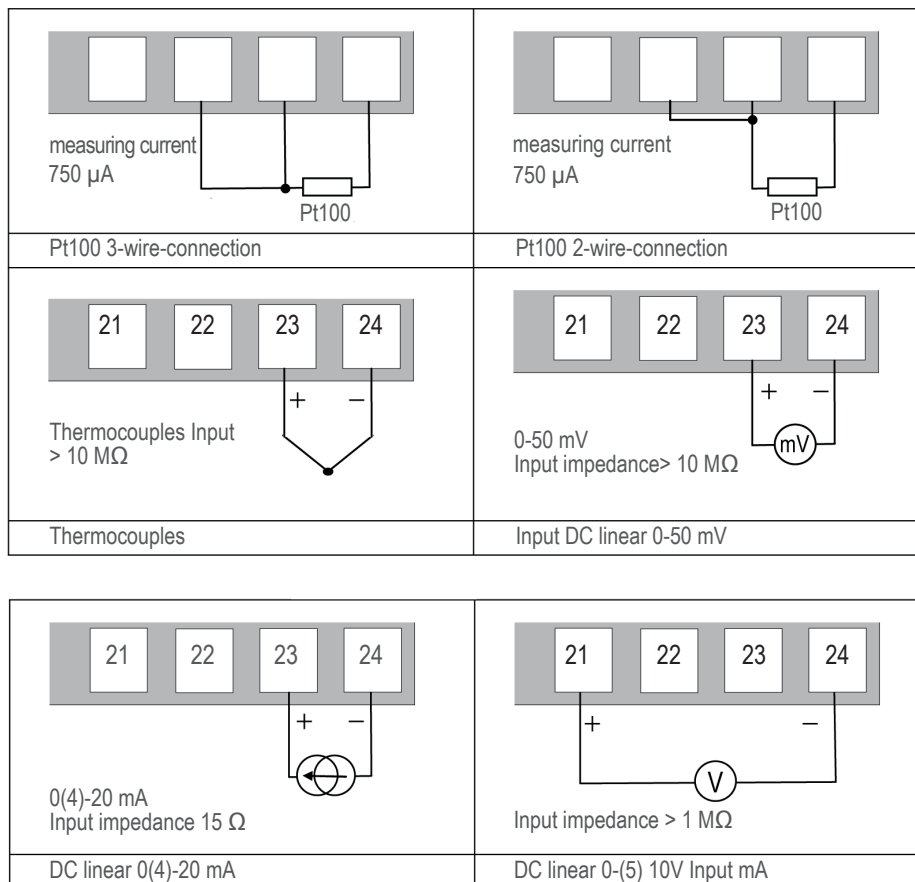

OPERATION MANUAL



Indicator N1500

For best measurement results, all Pt100 connection wires should have an identical electrical resistance (identical conductive material and the same length). This guarantees an optimal cable compensation. By using the 2-wire connection, the user has a reduced accuracy. In order to assure the accuracy specified in the specifications, the 3-wire-connection has to be used. The polarity of the sensor connections must be strictly observed to avoid incorrect measurements. The thermocouple extension cables should have the same type of the thermocouple used. Detailed information about the optimal use of different sensors can be found in the B + B catalog or on our website at: www.bb-sensors.com

5.4. Digital input

The indicator is equipped with a digital input to the terminals 13 and 14. The input can be activated for example by connecting a switch or something similar.

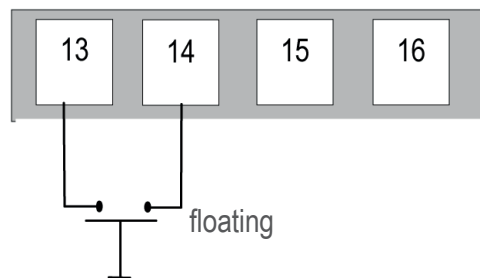

5.5. 24V DC output

The device provides a 24V DC power supply for external equipment. This output can be found at the terminals 16 and 17. The figure shows an example of the connection of a 4-20 mA transmitter in 2-wire technology, which is driven by the 24V DC output voltage.

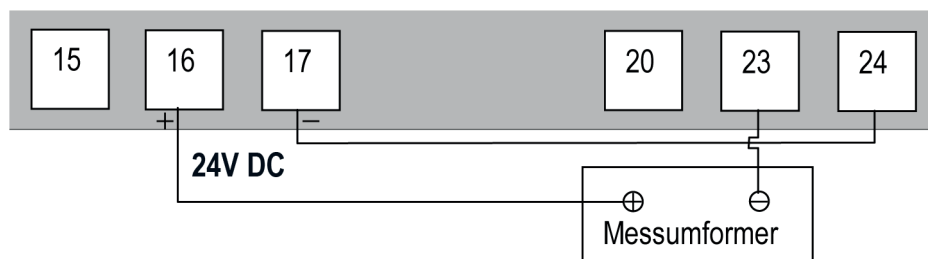

5.6. Analog output

As an option, the Indicator can be delivered with a 4-20 mA analogue output (terminals 29 and 30). Similar to a 4-20 mA transmitter, the measured values are issued as an linearized, analog current signal.

5.7. RS485 interface

As an option, the indicator can be delivered with an RS485 serial communication interface. The interface is located on the terminals 25, 26 and 27.

6. Operation

After power on, the indicator shows for several seconds the software version number. Then the display switches to the operating level, evaluate the input signal, temperature values on screen and display.

The prior to first operation the indicator should be fully configured. The user must set basic parameters such as sensor type (type), alarm setpoints (SP.AL1 and SP.AL2) etc..

The programming parameters are organized in 6 different levels:

1. Operation level
2. Alarm level
3. Function level
4. Configuration level
5. Linearization level
6. Calibration level



OPERATION MANUAL



Indicator N1500

6.1. Programm level flow chart

| Operation level | Alarm level | Function level | Configuration level | Linearization level | Calibration level |
|----------------------------------|--------------------|--------------------|---------------------|----------------------------|--------------------|
| Display | FU _{AL} 1 | FF _{Unc} | in _{tYP} | inP. 0 1 b 15 inP.30 | inLoc |
| AL _{ref} ⁽¹⁾ | FU _{AL} 2 | d IG. In | dPP05 | oUt.0 1 b 15 oUt.30 | inh ic |
| SP _{AL} 1 | hY _{AL} 1 | F ILt _r | Un it | | oU _{Loc} |
| SP _{AL} 2 | hY _{AL} 2 | oFSEt | S _{root} | | oU _{h ic} |
| | bL _{AL} 1 | bA _{Ud} | inLoL | | c J Lo |
| | bL _{AL} 2 | Ad _{rES} | inh iL | | h _{tYP} E |
| | AL. it 1 | | oU _{t.tY} | | |
| | AL. it 2 | | oU _{t.Er} | | |
| | AL.2t 1 | | | | |
| | AL.2t 2 | | | | |

| | |
|--|---|
| | Next Programm level |
| | Previous parameter in the current level |
| | Next parameter |

(1) This parameter is only accessible if the appropriate input type and configuration has been selected

(2) For access to the calibration level: Press min. 3 seconds, all levels are displays displayed briefly

6.2. Operation level

| Parameter | Parameter description |
|--|--|
| 88888 | Display the process variables. For Pt100 and thermocouples the temperature is displayed in °C or °F the value displayed. For 4-20 mA, 0-50 mV, 0-5 V and 0-10 mV input signals corresponds to the values shown the details of the linearization parameters in.LoL and in.kiL. At activated hold - function, the display alternately shows the actual temperature value and the last message Kold. At activated peak hold - function, the display alternately displays the maximum value and the message P.koLd. Disturbances are shown on the display as error messages that facilitates troubleshooting. For more information, see „Error Messages“ in this documentation. |
| AL _{ref} | Relative alarm reference-value. This parameter is displayed when any alarm is set to a differential alarm function. This value is used as a reference value used for the definition of relative value and band alarm function. |
| SP _{AL} 1 SP _{AL} 2 SP _{AL} 3 SP _{AL} 4 | Alarm setpoints. Defines the point of activation of the alarm, if the alarm functions are Lo or ki. In relative value and band alarm functions, defines the deviation from the reference value AL.ref. The alarm setpoints SP.AI3 and SP.AL4 are not available in the standard version. |



OPERATION MANUAL



Indicator N1500

6.3. Alarm level

Starting from the operating level, simultaneously press the back-key and the program key .

6.4. Alarm functions

7 different alarm functions are available. The alarm outputs can be used with different functions.

At ierr the alarm triggers when the sensor is broken or wrong connected.

SP.AL defines the trigger point at the minimum and maximum alarms.

In the differential alarms, Sp.AL defines the deviation of the alarm trigger point to the reference value AL.REF.

The following table lists all alarm functions, their codes and schematic action on the alarm relay.

| Parameter | Description |
|--|---|
| <i>FUR1</i> , <i>FUR2</i> , <i>FURL3</i> , <i>FURL4</i> | Alarm functions. Defines the alarm functions. In the standard version, only the alarms 1 and 2 are available. |
| | Alarm function Code Action |
| | Disabled <i>oFF</i> Alarm is off |
| | Input Error <i>iErr</i> The alarm is triggered when a sensor-error occurs. |
| | Low <i>Lo</i> |
| | differential low <i>hi</i> |
| | differential low <i>dIFLo</i> |
| | differential high <i>dIFhi</i> |
| | differential out <i>dIFoU</i> |
| | differential within <i>dIF.in</i> |

6.5. Special alarm features

The user can delay the switching alarm relative to these points. This is configured by setting the alarm hysteresis.

The initial blocking option inhibits the alarm from being recognized if an alarm condition is present when the indicator is first energized. The alarm will be enabled only after the occurrence of a non alarm condition followed by a new occurrence for the alarm.

The alarm timer function give the user the possibility to delay the release point of the alarm time or spend the alarm as a pulse or pulse series.

The following table shows these functions and their description.



OPERATION MANUAL



Indicator N1500

| Parameter | Description | | | |
|--|--|----------------|-------------|--------|
| hYAL 1 hYAL 2 hYAL 3 hYAL 4 | Alarm Hysteresis: This parameter defines the difference between the on and off of the observed alarms. The off value will be delayed by values set here. The on values are not affected by the hysteresis. For example, band wide alarm (internal Dif.In) | | | |
| | Without Hysterese | With Hysterese | | |
| | | | | |
| bLAL 1 bLAL 2 bLAL 3 bLAL 4 | Alarm suppression after turn on. After turn-on the indicator, the alarm occurs until a new alarm condition occurs. | | | |
| ALt 1 ALt 2 ALt 1 ALt 2 ALt 1 ALt 2 ALt 1 ALt 2 | Alarm timer: The alarm can also be equipped with a timer function. So the user can individually set the alarm triggering to be delayed, a single or a series of pulses on the outputs. The delay time, pulse width and pulse period to give can be set in the time parameters at AL.t1 and AL.t2. To disable this function, set T1 and T2 to zero. | | | |
| | Function | ALt 1 | ALt 2 | Action |
| | Normal operation | 0 | 0 | |
| | Delay | 0 | 1 to 6500 s | |
| | Pulse | 1 to 6500 s | 0 | |
| | Puls period | 1 to 6500 s. | 1 to 6500 s | |



OPERATION MANUAL



Indicator N1500

7. Function level

7.1. Min- und Max-Functions

The N1500 indicator permanently stores the maximum and minimum values. To display these values manually, press and hold in the operating level or the key. To display the normal mode release the button. To delete the stored values and trigger the Min- and Max- values for storing a new time period, press both buttons and .

7.2. Die Function key (F-key)

The function key on the front panel and the digital input on the back of the indicator can be programmed to perform specific functions. The functions, available for this purpose, will be configured in functional level and are described in the following table,

| Parameter | Description |
|--|--|
| <i>FFunc</i> | Describes the functions for the the function-key (F key). |
| <i>ETHERIA ILR- bLEopt IonS RrE:</i> | F- key disabled |
| <i>hold</i> | While pressing the F-key, the current display is „frozen“. The display will alternate this value and the message hold. In the background, current measurements are continued. When re-pressing the F-key the indicator changes back to normal display. |
| <i>rSt</i> | Reset. When the F.Func Parameter is set, the internal memory (max and min values) are cleared each time you press the F-key and a new Min./ Max. cycle startet. |
| <i>Phol</i> | The Peak-Hold Function shows the largest measured value since the last action on the F-key. Each additional press of the F-key starts a new peak-hold cycle. The display alternately shows the maximum value and the message of peak hold. To disable the peak hold mode, the user must set the parameters back to FFunc off or some other value. |
| <i>SELF</i> | The process is monitored and the auto-adaptive mode is automatically started by the control, when the performance of the indicator gets bad.After a feature-cycle the indicator starts evaluating the data with detecting the performance-benchmark, which has been evaluated in the previous features. This phase is proportional to the response time of the process and is displayed by the blinking of the TUNE display. Do not turn off the controller whilst this feature. |
| <i>rSLF</i> | Starts the automatic coordination after this and switches to the SELF mode when finished. |
| <i>tkht</i> | Like SELF mode. Additional to the auto-adaptive feature the indicator runs the automatic channel search, when the control is -RUN=YES or when the controller is switched on. |

7.3. Digital input functions

Similar to the F-key , the digital-input can be programmed to run at a certain function on its activation. This works with the parameter DIG.In and is explained in the following table.

| Parameter | Description |
|---------------|---|
| <i>dIG.In</i> | Digital input functions: Specifies the function to be executed when the digital input is activated. The following options are available: off: disabled Hold: Hold Functions reset: Reset Phold: Peak Hold |



OPERATION MANUAL



Indicator N1500

7.4. Filter, Offset and serial communication

| Parameter | Functions |
|--------------------|---|
| <i>F i L T e r</i> | Input digital filter: Adjustable from 0 to 20. This parameter is used to smooth variations of the measured values 0 (zero) means, the filter is turned off, 20 means maximum filtering. The higher the filter value is, the slower the response time of the device. |
| <i>o F S E t</i> | Display Offset: The value set here will be automatically added to the actual measured values in order to compensate possible, known sensor error. |
| <i>b A U D</i> | Baud Rate: Speed of the serial communication via the optional RS485 interface. The entry is in bps (bits per second). Options are: 1200, 2400, 4800, 9600, 19200, 38400 or 57600 bps. |
| <i>A d d r E S</i> | Communication address: Address to identify the indicator. |

D1 = D Bidirectional data line

D0 = D Inverted bidirectional data line

C = GND Grounding (optional). Improves the quality of communication over long cables.

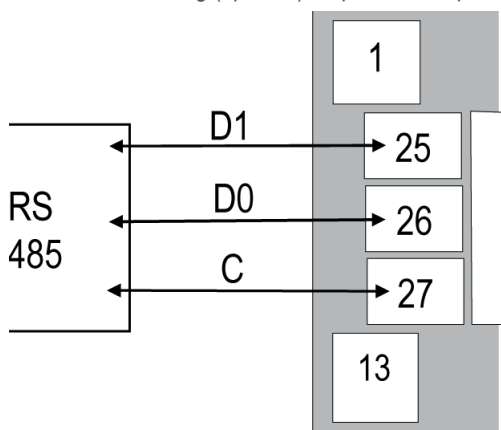

The optional RS485 communication-interface operates as a result of the indicator device (slave) and is given as a command. All commands from the PC (master) started. The addressed device processes the command and sends back a response.

Features:

- Compatibility with 2-wire RS485 bus
- Up to 31 units (slaves) in a network device
- Up to 247 units can be addressed via the RTU-Modbus
- Maximum network at 1200 m
- Shock after receiving a command: Maximum 2 ms after sending the last byte
- Communication signals are electrically isolated from the rest of the unit
- Baud Rate: 1200, 2400, 4800, 9600, 19200, 38400 or 57600 bps
- Data bits: 8, parity none, stop bits: 1
- Protocol: Modbus (RTU)



OPERATION MANUAL



Indicator N1500

8. Configuration level

8.1. Input type and display parameter

| Parameter | Description |
|---------------|---|
| <i>inType</i> | Sensor typ: This parameter must be configured first. The supported sensor types are: |
| Sensor | Type 4 - 20 mA lin. Sensors |
| <i>tcJ</i> | Thermocouple type J <i>L inJ</i> |
| <i>tcK</i> | Thermocouple type K <i>L inK</i> |
| <i>tcT</i> | Thermocouple type T <i>L inT</i> |
| <i>tcN</i> | Thermocouple type N <i>L inN</i> |
| <i>tcR</i> | Thermocouple type R <i>L inR</i> |
| <i>tcS</i> | Thermocouple type S <i>L inS</i> |
| <i>Pt100</i> | Pt100 <i>L inPt</i> |
| <i>tcB</i> | Thermocouple type B <i>L inB</i> |
| <i>Pt100</i> | Pt100 <i>L inPt</i> |
| <i>SELF</i> | The process is monitored and the auto-adaptive mode is automatically started by the control, when the performance of the indicator gets bad. After a feature-cycle the indicator starts evaluating the data with detecting the performance-benchmark, which has been evaluated in the previous features. This phase is proportional to the response time of the process and is displayed by the blinking of the TUNE display. Do not turn off the controller whilst this feature. |
| <i>rSELF</i> | Starts the automatic coordination after this and switches to the SELF mode when finished. |
| <i>Auto</i> | Like SELF mode. Additional to the auto-adaptive feature the indicator runs the automatic channel search, when the control is -RUN=YES or when the controller is switched on. |

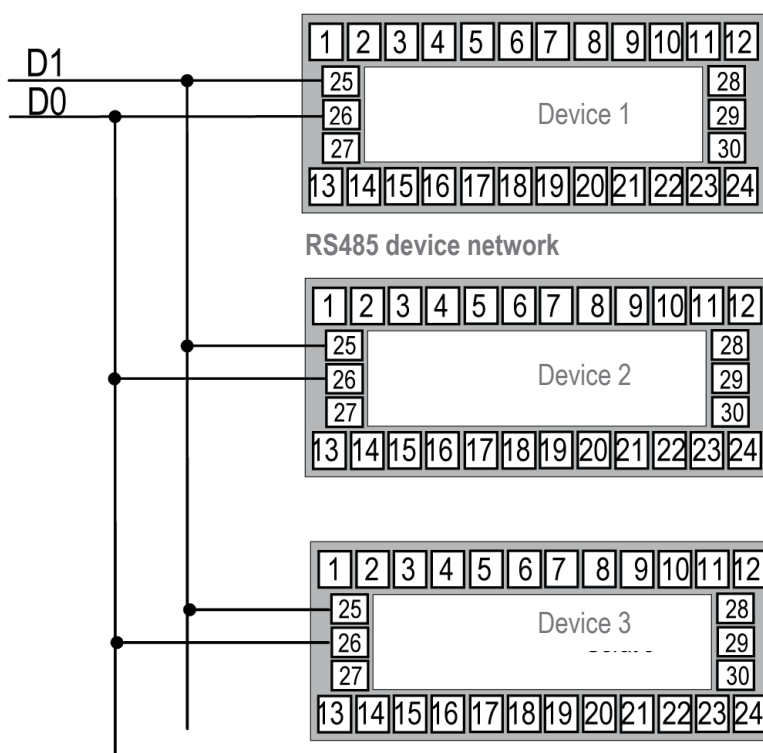

OPERATION MANUAL

B+B

SENSORS

Indicator N1500

| Parameter | Description | | |
|---------------|---|---------|---------------|
| <i>InL TP</i> | Analogue inputs | | |
| | Linearization adjustable between -31000...+31000 | | |
| | Type | | |
| | Customer-specific linearization | | |
| | <i>0-10</i> | 0-10V | <i>c.0-10</i> |
| | <i>0-5</i> | 0-5V | <i>c.0-5</i> |
| | <i>0-50</i> | 0-50 mV | <i>c.0-50</i> |
| | <i>0-20</i> | 0-20 mA | <i>c.0-20</i> |
| | <i>4-20</i> | 0-20 mA | <i>c.4-20</i> |
| <i>dPPOS</i> | Decimal point: Determines the position of the decimal point on the display. This parameter is only available for the analog input types 0-50 mV, 0-5V, 0-10V, 0-20 mA and 4-20 mA. In the standard sensor types, the decimal position is predefined. | | |
| <i>dUn It</i> | Temperature unit: Sets the unit of the display. Available options are: °C or °F. This parameter is not available for the analog input types 0-50 mV, 0-5V, 0-10V, 0-20 mA and 4-20 mA. | | |
| <i>Sroot</i> | Square root: This parameter is only available if an analog input type is selected at the parameter In typ. (0-50 mV, 0-5V, 0-10V, 0-20 mA and 4-20 mA). Press YES to square root the measured values (within the limits defined InloI and inh Il). If the input signal is less than 1%, the value is displayed in InloI. | | |
| <i>SELF</i> | The process is monitored and the auto-adaptive mode is automatically started by the control, when the performance of the indicator gets bad. After a feature-cycle the indicator starts evaluating the data with detecting the performance-benchmark, which has been evaluated in the previous features. This phase is proportional to the response time of the process and is displayed by the blinking of the TUNE display. Do not turn off the controller whilst this feature. | | |
| <i>rSLF</i> | Starts the automatic coordination after this and switches to the SELF mode when finished. | | |
| <i>t9ht</i> | Like SELF mode. Additional to the auto-adaptive feature the indicator runs the automatic channel search, when the control is -RUN=YES or when the controller is switched on. | | |

8.2. Scaling and display range for analoge inputs

| Parameter | Parameterdescription |
|---------------|---|
| <i>SCALE</i> | Scale: Sets the display range for the analog inputs (0-50 mV, 0-5V, 0-10V, 0-20 mA and 4-20 mA). Available options are: 0 Adjustable display of -31000 to +31000. 1 Adjustable display of 0 to +60000. 2 Adjustable display of 0 to +120000. Only even values are displayed. The adjusted scaling affects not only the measured value but also the alarm set to points and the offset values. |
| <i>InLoI</i> | Input Low Limit: Defines the lowest reading for the analog input signals (0-50 mV, 0-5V, 0-10V, 0-20 mA and 4-20 mA) of the lowest signal value is assigned. Example: input = 4 - 20, In.loI = -20. This means that at 20 mA input the value -20 on the is displayed. |
| <i>inh Il</i> | Input High Limit: Defines the maximum display value for the analog input signals (0-50 mV, 0-5V, 0-10V, 0-20 mA and 4-20 mA) signal of the highest value is assigned. Example: input = 4 - 20, In.hI = +100. This means that at 20 mA input the value +100 is displayed. |
| <i>oUl.oI</i> | Low-Limit for analoge 0(4)-20 mA Measurement transmission (optional): Defines the measurement value which results in a 0 mA (or 4 mA) current at the analog output. |
| <i>oUh Il</i> | High-Limit für die analoge 0(4)-20 mA Measurement transmission (optional): Defines the measurement value which is applied in a 20 mA current at the analog output. |
| <i>oUt.tY</i> | Analog Output: Results options are: 0-20 mA or 4-20 mA |
| <i>oUt.Er</i> | Output error: Defines the type of transfer when an error occurs. Available options are: <i>da</i> : Transmission < 4 mA <i>UP</i> : Transmission > 20 mA |



OPERATION MANUAL



Indicator N1500

8.3. Linearization level

| Parameter | Parameter description |
|---------------------------------|---|
| <i>InP.01</i> bis <i>InP.30</i> | Linearization level: These parameters define from the beginning to the end up to 29 linearisation segments of the input signal. The entries must be made in units of the selected input signal (0-50 mV, 4-20 mA or 0-5 V). |
| <i>out.01</i> bis <i>out.30</i> | These parameters defines the values, which are displayed when InP01 to inp.30 linearization segments meet. Entries are made in the desired display unit. The values must be within the parameters defined by the In.lol and n.hil area. |

The following figure shows the relationship between the Inp.hh and out.hh parameters.

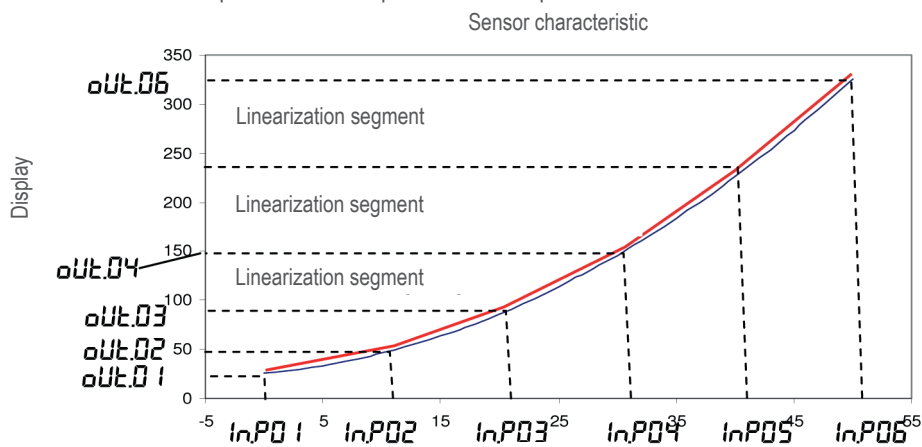

8.4. Calibration level

All inputs and outputs are precalibrated. The calibration level should be chosen only by technically versed, well-trained and -equipped users. If the calibration level has been unwanted chosen, please do not activate the and keys. Leave the calibration level by pressing the key for more than 3 seconds.

| Parameter | Parameter description |
|----------------|---|
| <i>In.Loc</i> | Input Low Calibration: Set the temperature sensor low calibration (offset). The display shows only the corrected temperature and not the offset added. A signal simulator should be used to inject a low value signal to properly adjust the offset. |
| <i>In.hic</i> | Input High Calibration: Sets the sensor input circuit gain or high calibration. A signal simulator should be used to inject a high value signal to properly adjust the offset. |
| <i>out.Loc</i> | Analog Output Low Calibration: Offset-Calibration for the analog output. |
| <i>out.hic</i> | Analog Output Span Calibration: Gain-Calibration for the analog output. |
| <i>c.jLo</i> | Cold Junction Calibration: Sets the cold junction offset calibration. A signal simulator should be used to properly adjust this parameter. |
| <i>h.tYPE</i> | Hardware type: This parameter is similar to the current firmware of the hardware (including all options) of the indicator and should not be changed. 2 Alarm 3 2 Alarm and 4-20 mA 19 2 Alarm and RS485 35 2 Alarm, 4-20 mA and RS485 51 4 Alarm 15 4 Alarm and 4-20 mA 31 4 Alarms and RS485 47 4 Alarms, 4-20 mA and RS485 63 |

If a re-calibration of the instrument is necessary, follow the steps described below. You need to calibrate a signal simulator that matches to the type of sensor to be calibrated.



OPERATION MANUAL



Indicator N1500

Input calibration:

1. Set input type to the input type you want to calibrate.
2. At the entrance of the selected sensor type, you inject a signal which is a known controller value (temperature) exactly above
3. Select the parameter in the calibration level In.LC. Use the and keys to set the display value that corresponds the setted signal.
4. To receipt a selected sensor type, set a signal that corresponds to a known value controller (temperature) below the maximum value of the sensor range.
5. Select the parameter in the calibration level In.HC. Use the and keys to set the display value that corresponds to the injected signal.
6. Repeat steps 2 through 6 until no new adjustment is necessary.
7. You can calibrate the controller also for a limited temperature range. This can lead to improved accuracy.
8. When checking with a calibrator of the Pt100 input, make sure that these same excitation current is used as the controller (750 uA).

9. Error messages

Connection and configuration errors state for most of the problems with the use of the controller. A final revision of parameters will save time and further losses.

Error messages are displayed to help the user to identify possible problems..

| Error messages | Possible cause |
|----------------|---|
| UUUU | Process temperature is above the selected sensor range. |
| rrrr | Process temperature is below the selected sensor range. |
| ---- | Open input. It is no sensor connected, or the connected sensor is broken. |
| Err 1 | The cable of the Pt100 sensor has a large electrical resistance or the sensor is connected incorrectly. |

10. Serial number

The serial number of the indicator can be activated, by pressing the button. The serial number will be displayed for 3 seconds. Every power-on of the indicator shows the software version-number for a few seconds in the display.

11. Technical data

| Features | Values |
|--------------------|--|
| Inputs | Thermocouples type J, K, T, E, N, R, S and B, Pt100 with 3-wire-connection, 4-20 mA, 0-50 mV, 0-10 V |
| Input impedances | 0...50 mV and thermocouples: 10 mΩ 0...5 V and 0...10 V: 15Ω 0(4)...20 mA: 15Ω Pt100: 175 μA |
| Measurement ranges | J -130...+940°C (-202...+1724°F) K -200...+1370°C (-328...+2498°F) T -200...+400°C (-328...+752°F) E -100...+720°C (-148...+1328°F) N -200...+1300°C (-328...+2372°F) R 0...+1760°C (+32...+3200°F) S 0...+1760°C (+32...+3200°F) B +500...+1800°C (+932...+3272°F) PT100 -200...+850°C (-328...+1562°F) 0-20 mA: Linear programmable from -31000...+31000 0-50 mV: Linear programmable from -31000...+31000 0-10 V: Linear programmable from -31000...+31000 All the input signals can be customized linearized |
| Accuracy | Thermocouples J, K, N and T: ±0,25% of the full range ±1 °C Thermocouples R und S: ±0,25% of the full range ±3 °C Pt 100: ±0.2% of the full range 4-20 mA, 0-50 mV and 0-10 V: 0.15% of the full range |
| Outputs | 2 alarms relays SPST, max. load 3A/250V AC/DC Optional: 24V DC for remote transmitter |



OPERATION MANUAL



Indicator N1500

| | |
|------------------------------|---|
| Measurement rate | 5/s (5 Hz) - (15/s for 0-50 mV, 4-20 mA, 0-5 V and 0-10 V input types) |
| AD resolution | 128000 intern, 62000 Display |
| Power supply | 100...240V DC ($\pm 10\%$), 50-60 Hz or 24V AC/DC ($\pm 10\%$), max. 7,5 VA |
| Operating conditions | Interior rooms, 0...+55°C, 20...85% r.F. |
| Ingress protection | IP65 at the front panel |
| Dimensions (W x H x D) | 96 x 92 x 48 mm (1/16 DIN) |
| Panel cut-out | 93 x 45 mm |
| Weight | 250 g |
| Elektromagnetic conductivity | EN 61326-1:2013-07 |
| Material | Front: Polycarbonate UL94 V-2, Back: ABS and PC UL94 V-0 |

12. Ordering information

| Description | Articlenumber |
|---|---------------|
| Indictaor N1500 with 100 bis 240V AC | 0556 0105 |
| Indicator N1500 with 24 V AC/DC | 0556 0105-01 |
| Indicator N1500 with 4...20 mA | 0556 0105-02 |
| Indicator N1500 24 V AC/DC with RS485-interface | 0556 0105-03 |

Questions

If you still have questions concerning this product of B+B Thermo-Technik GmbH, please do not hesitate to contact us at:

B+B Thermo-Technik GmbH
Heinrich-Hertz-Straße 4
D-78166 Donaueschingen

Tel.: +49 771 83160
Fax: +49 771 831650
E-Mail: info@bb-sensors.com

We wish you a successful measuring!

Your Temperature-Partner
B+B Thermo-Technik GmbH

All technical information in this document are proved by us with high accuracy and shall inform you about all application possibilities. This information is not confirmed by us and need to be proved by every user in regard to his intended use of the equipment. All foreign trade mark rights need to be considered.

Edition 12/ 2011. This manual substitutes all former editions.

